

Advanced EMC/RFI filter concept with minimum leakage current

SCHAFFNER

energy efficiency and reliability



- Compact state-of-the-art filter concept
- Light weight plastic enclosure design
- Minimized filter leakage current
- Hinged safety covers
- Revolutionary embedded filter terminals
- Chassis or DIN-rail mounting option
- Selectable performance level
- Environmental friendly design without potting compound

Approvals



Technical specifications

Maximum continuous operating voltage:	3x 520/300VAC
Operating frequency:	dc to 60Hz
Rated currents:	10 to 50A @ 50°C
High potential test voltage:	P → E 2000VAC for 2 sec (HL types) P → E 3000VDC for 2 sec (HP types) P → P 2250VDC for 2 sec
Protection category:	IP00 (protection according to VBG 4)
Overload capability:	4x rated current at switch on, 1.5x rated current for 1 minute, once per hour
Temperature range (operation and storage):	-25°C to +100°C (25/100/21)
Flammability corresponding to:	UL 94V-2 or better
Design corresponding to:	UL 1283, CSA 22.2 No. 8 1986, IEC/EN 60939
MTBF @ 50°C/400V (Mil-HB-217F):	>200,000 hours

Typical electrical schematic

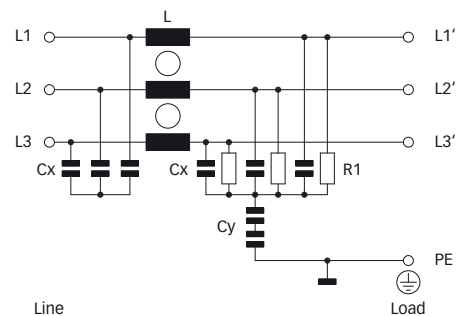

Features and benefits

- FN 3025 filters are designed for traditional chassis mounting.
- For extra fast installation, FN 3026 filters can comfortably be snapped-in on TS 35 DIN-rails.
- Two different performance levels are offered (L types, P types). The suitable filter can be selected by choosing the required performance level, the admissible leakage current and the preferred installation style.
- A plastic housing and a metal ground plate are cleverly combined to get the lowest possible product weight without compromising EMC behavior.
- The embedded jump-terminal system from Schaffner guarantees user-friendly handling as well as fast and reliable electrical connection.
- Captive hinged protective covers contribute to overall safety by offering protection against unintended contact with live conductors. They are included in the standard delivery package without causing extra cost.
- Very low leakage current values make these filter ranges ideally suitable for use in Japanese electricity networks as well as in applications which set value on safety and reliability.

Typical applications

- Applications with the requirement for extremely compact filter solutions
- Applications with tough leakage current requirements or sensitive earth leakage detectors
- Applications with insufficient internal filtering or moderate interference levels
- Automation equipment
- Motor drives and servo drives with short motor cables
- Applications including stepping motors
- Semiconductor manufacturing equipment
- Electrical cabinets
- Three-phase power supplies
- Medical equipment (not patient-coupled)

Filter selection table

Filter	Rated current @ 50°C (40°C)	Typical drive power rating*	Leakage current** @ 480VAC/50Hz	Power loss @ 25°C/50Hz	Input/Output connections 	Weight [kg]
	[A]	[kW]	[mA]	[W]		
FN 3025HL-10-71	10 (10.7)	5.5	0.4	4.8	-71	0.52
FN 3025HL-20-71	20 (21.4)	11	0.4	6.2	-71	0.52
FN 3025HL-30-71	30 (32.1)	18.5	0.4	7.0	-71	0.54
FN 3025HL-50-72	50 (53.5)	30	0.4	10.5	-72	0.93
FN 3025HP-10-71	10 (10.7)	5.5	2.5	4.8	-71	0.52
FN 3025HP-20-71	20 (21.4)	11	2.5	6.2	-71	0.52
FN 3025HP-30-71	30 (32.1)	18.5	2.5	7.0	-71	0.54
FN 3025HP-50-72	50 (53.5)	30	2.5	10.5	-72	0.93
FN 3026HL-10-71	10 (10.7)	5.5	0.4	4.8	-71	0.56
FN 3026HL-20-71	20 (21.4)	11	0.4	6.2	-71	0.56
FN 3026HL-30-71	30 (32.1)	18.5	0.4	7.0	-71	0.58
FN 3026HL-50-72	50 (53.5)	30	0.4	10.5	-72	0.98
FN 3026HP-10-71	10 (10.7)	5.5	2.5	4.8	-71	0.56
FN 3026HP-20-71	20 (21.4)	11	2.5	6.2	-71	0.56
FN 3026HP-30-71	30 (32.1)	18.5	2.5	7.0	-71	0.58
FN 3026HP-50-72	50 (53.5)	30	2.5	10.5	-72	0.98

* Calculated at rated current, 480VAC and cos phi = 0.8. The exact value depends upon the efficiency of the drive, the motor and the entire application.

** Maximum leakage under normal operating conditions. Note: if two phases are interrupted, worst case leakage could reach up to 10 times higher levels (at 520VAC/60Hz).

Typical filter attenuation

Per CISPR 17; A = 50Ω/50Ω sym; B = 50Ω/50Ω asym; C = 0.1Ω/100Ω sym; D = 100Ω/0.1Ω sym

10 and 20A HL types

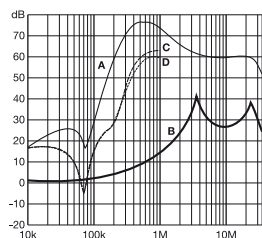

10 and 20A HP types

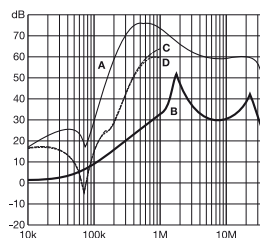

30 and 50A HL types

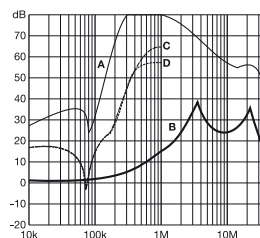

30 and 50A HP types

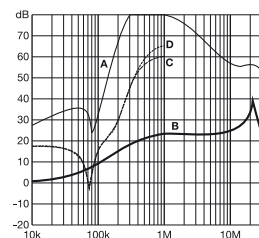

Installation

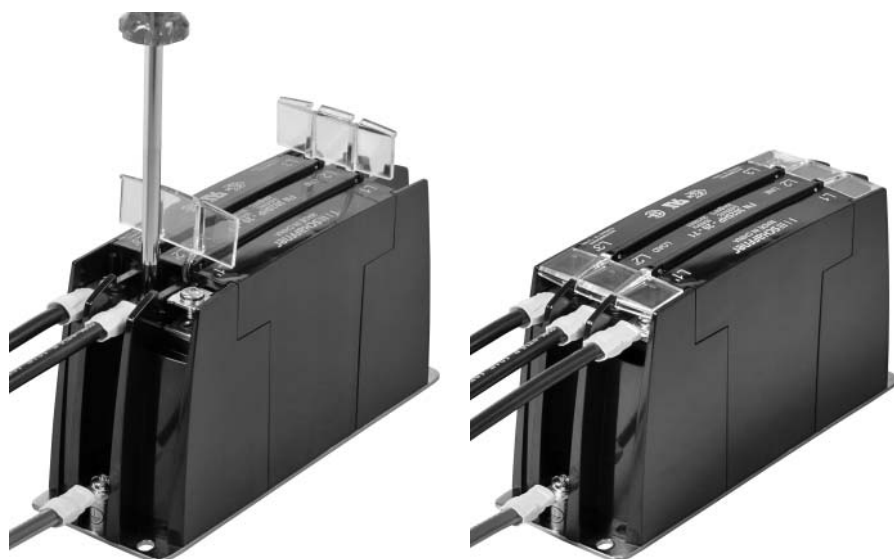

FN 3025/FN 3026 are delivered with closed plastic covers and unfastened terminals. To install the filter please proceed as follows:

- Mount the filter on a metal surface with four screws or snap it onto a TS 55 DIN-rail.
- First connect the green/yellow wire to the earth stud of the filter.
- Gently lift the two hinged plastic covers.
- Connect phase wires with cable lugs by pushing down and tightening the screws.
- Please note the torque recommendation on top of the filter.
- Push the covers back into their locked position to finish the filter installation.

Mechanical data

FN 3025

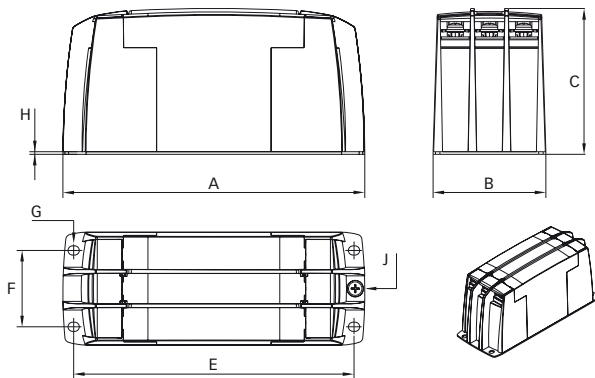

FN 3026

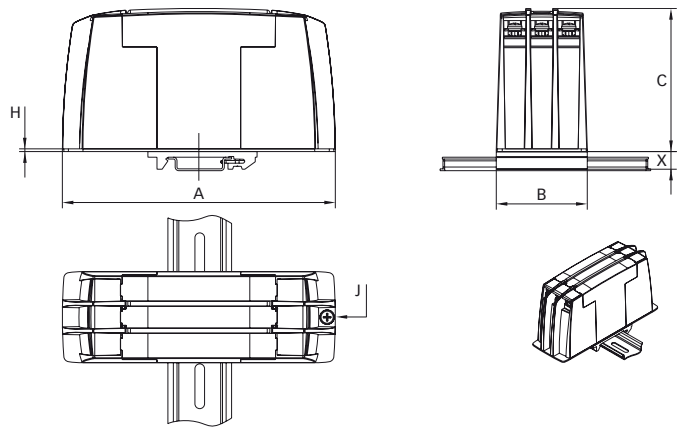

Dimensions

	FN 3025				FN 3026			
	10A	20A	30A	50A	10A	20A	30A	50A
A	150	150	150	177	150	150	150	177
B	50	50	50	65	50	50	50	65
C	78	78	78	84	78	78	78	84
E	140	140	140	162				
F		32	32	44				
G	4.3 x 5.5	4.3 x 5.5	4.3 x 5.5	5.3 x 6.5				
H	1.5	1.5	1.5	1.5	1.5	1.5	1.5	1.5
J	M4	M4	M4	M5	M4	M4	M4	M5
X					9.7	9.7	9.7	9.7

All dimensions in mm; 1 inch = 25.4mm
Tolerances according: ISO 2768-m / EN 22768-m

Filter input/output connector cross sections

	-71 (10A)	-71 (20A)	-71 (30A)	-72 (50A)
Flex wire	1.3 - 2.5mm ²	4 - 6mm ²	8 - 10mm ²	16 - 20mm ²
AWG type wire	AWG 16 - AWG 13	AWG 12 - AWG 10	AWG 8 - AWG 7	AWG 5 - AWG 4
Ring/fork lug (W/d)*	max. 11mm (9.5mm)/ min. Ø4.3mm**	max. 11mm (9.5mm)/ min. Ø4.3mm**	max. 11mm (9.5mm)/ min. Ø4.3mm**	max. 16.5mm (15mm)/ min. Ø5.3mm**
Recommended torque	1.0 - 1.2Nm	1.0 - 1.2Nm	1.0 - 1.2Nm	1.9 - 2.2Nm

* Schaffner recommends the use of insulated and UL-recognized ring lugs or fork lugs of the appropriate size.

** Specification in () relates to earth connector.

Please visit www.schaffner.com to find more details on filter connectors.

